

Yield and quality of crops from organic mixed cropping systems with oil crops

Hans Marten Paulsen¹, Bertrand Matthäus², Simone Seling³

¹Institute of Organic Farming, Johann Heinrich von Thunen-Institut, Federal Research Institute for Rural Areas, Forestry and Fisheries, Westerau, Germany,
hans.paulsen@vti.bund.de

^{2,3}Department of Safety and Quality of Cereals, Max Rubner-Institut, Federal Research Institute of Nutrition and Food Department of Safety and Quality of Cereals, Münster², Detmold³, Germany



Mixed cropping with oil crops



Peas and false flax

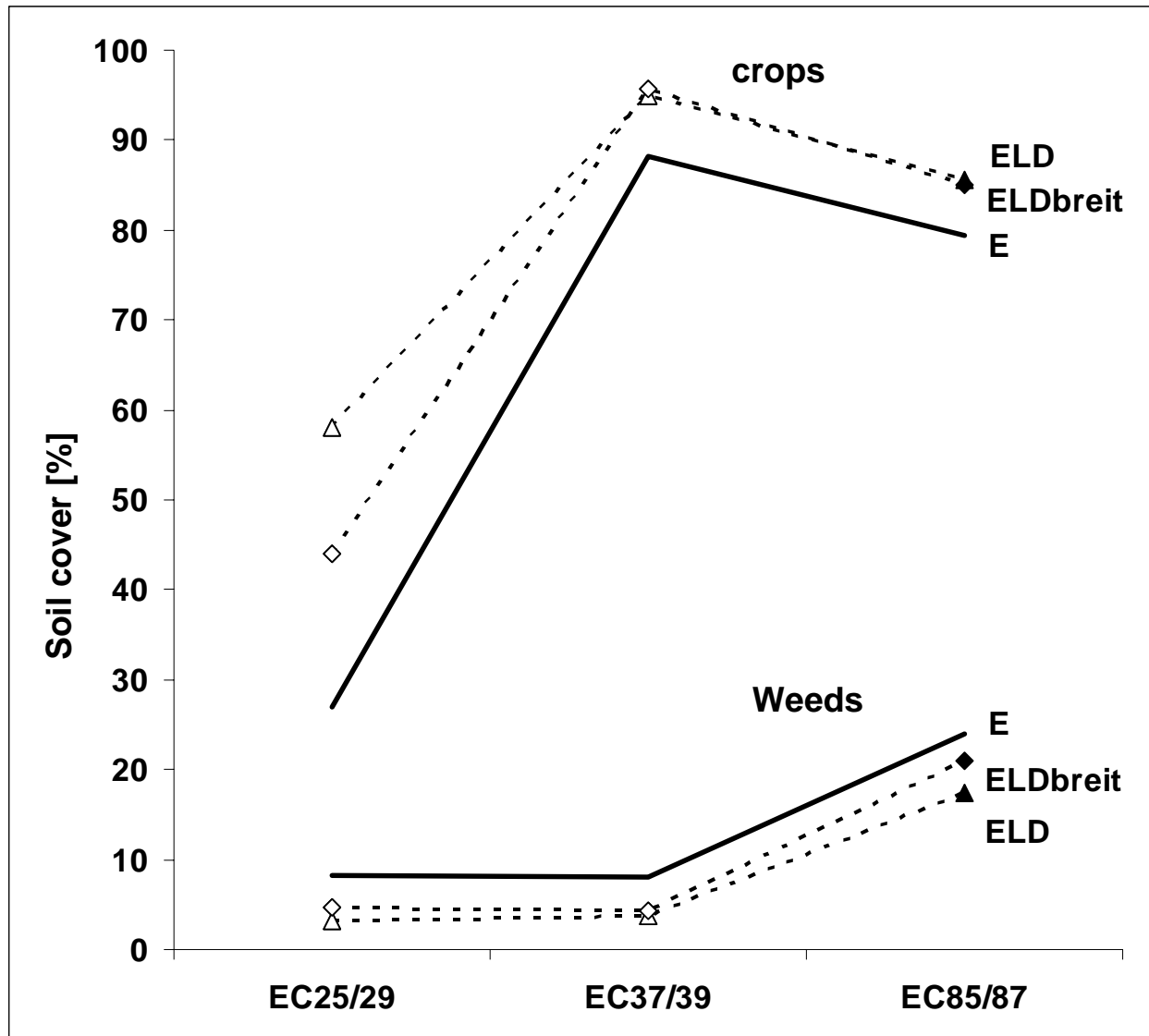

E = peas
LD = false flax

Soil cover of peas in sole cropping and in mixed cropping with false flax (Paulsen et al. 2007)

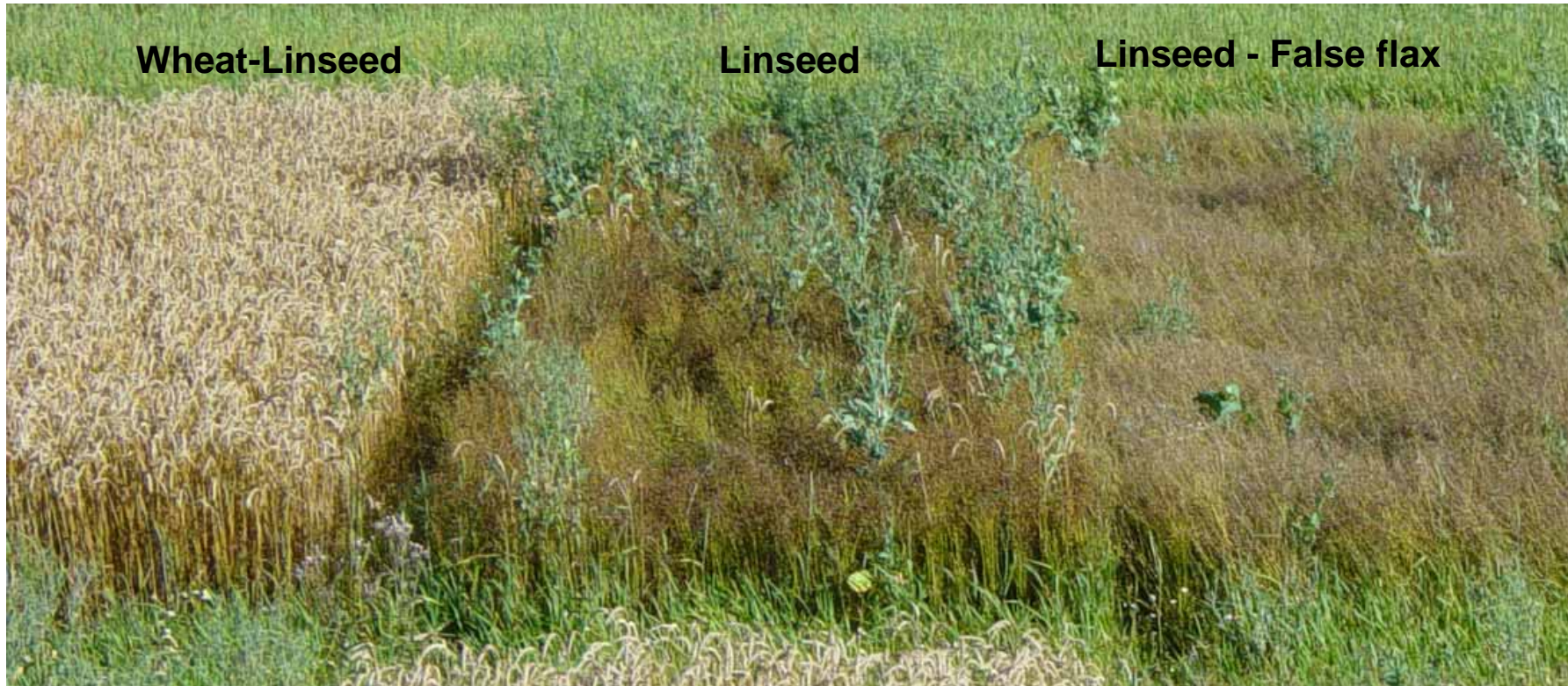

Reduced thistle and rapeseed density in mixed cropping systems with linseed compared to sole cropped linseed (Trenthorst 2004)

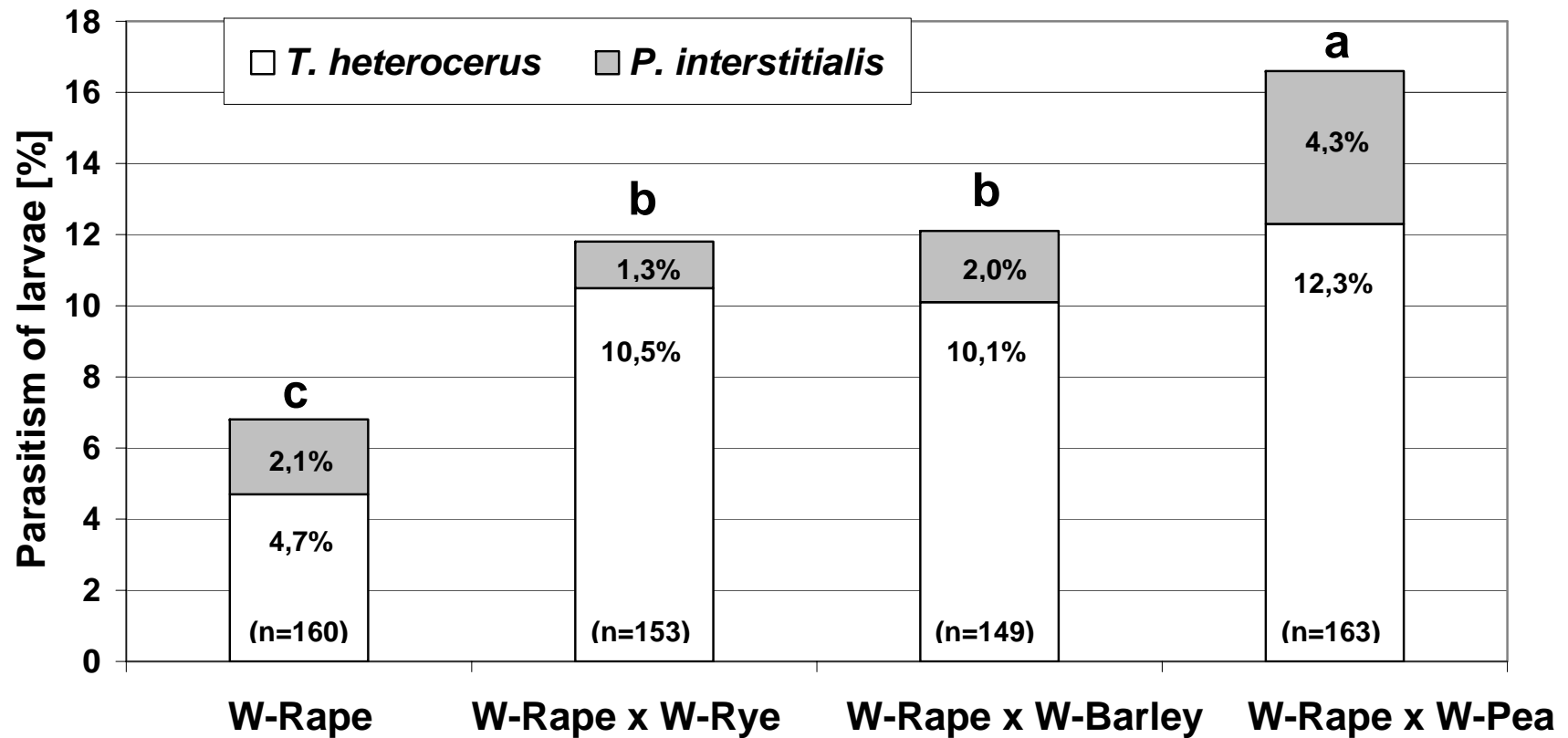

Parasitism of *M. aeneus* larvae by *T. heteroceris* und *P. interstitialis* grown in sole and mixed cropping of winterrape (Kühne und Ulber 2007)

Land equivalent ratio (LER)

Combined relative yield is higher than single yields in sole cropping e. g. 70 % + 40 % = 110 %

2004	Safflower	False flax	LER
Mixed crop [t ha ⁻¹]	1.5	0.6	
Sole crop [t ha ⁻¹]	2.3	1.3	
RY [%]	65	46	111

2 ha sole cropping: 2.3 t safflower + 1.3 t false flax

2 ha mixed cropping: 3.0 t safflower + 1.2 t false flax



Safflower/false flax, Trenthorst 2005

Seed yields [t ha⁻¹ dry matter] of the components in different mixed cropping systems and in sole cropping, (maximum values of four sites and two years in Germany and means of LER 2004 and 2005)

	All Sites LER	Means of one site maximum at ^a	
		1 st crop	oil-crop
Peas x False flax	1.4	3.2/0.1	0.7/1.7
Peas x Spring rape	^b	3.2/0.1 ^b	3.2/0.1 ^b
Peas x white Mustard	1.2	2.5/0.2	0.7/1.6
Blue lupins x safflower	1.1	1.1/0.7	0.9/2.0
Blue Lupins x False flax	1.3	1.7/0.1	1.1/1.5
Linseed x false flax	1.1	0.5/0.1	0.3/2.1
Spring wheat x false flax	1.1	4.1/0.4	4.1/0.7
Spring wheat x Linseed	1.0	4.8/0.3 ^c	4.8/0.3 ^c
Winter Peas x Winter Rape	1.9	0.9/0.2	0.2/0.8
Winter Barley x Winter Rape	0.8	4.1/0.1 ^d	0.2/0.7 ^d
Winter Rye x Winter Rape	0.8	4.7/0.1	0.3/0.2

^afirst crop/oil-crop, ^bSR destroyed by *M. aneus* at most sites

^csame site and year ^dsame site different years

Green house gas (GHG) emissions of different cropping systems with oil crops; GHG-reduction through the production of vegetable oil as a substitute for diesel; yield losses for food and forage caused by the cropping system, and/or the use of vegetable oil as fuel and remaining food and forage yield

	Yield losses for food and forage [kg ha ⁻¹]	Food and forage yield [kg ha ⁻¹]	Vegetable oil yield [kg ha ⁻¹] Substitution of fossil fuel [kg]	^a GHG emissions cropping system CO ₂ eq. [t ha ⁻¹ a ⁻¹]	^c GHG reduction by substitution of fossil fuel CO ₂ eq. [t ha ⁻¹ a ⁻¹]
Clover x rapeseed	*	700-1000 oilcake	300-500	0.6 + 2.9	1.1-1.9
Rapeseed	300-500 oil	700-1000 oilcake	300-500	2.9	1.1-1.9
Peas x false flax	0-200 peas	1500-4000 peas	130-240	3.4 + 0.02 ^b	0.5-0.9
Wheat x false flax	200-500 wheat	30-45 wheat	60-120	3.0 ^d + 0.02 ^b	0.2-0.4
Linseed	280-450 oil	540-900 oilcake	280-450	*	1.0-1.7

^adata from Nemecek et al. 2005, ^b15.6 kg ha⁻¹ CO₂ eq. for additional input for false flax in mixed cropping (Sergis-Christian and Browsers 2005), ^cdiesel fuel: CO₂ eq. 313,6 g kwh⁻¹, heating value 11,83 kwh kg⁻¹, together 3711 g kg⁻¹ CO₂ eq. (Fritsche and Schmidt 2007), ^destimation: Mean of values for winter wheat 3.4 and spring barley 2.7, *no data available

Determined quality parameters of oil crops, legumes and cereals

Oil crops

Oil content (ISO 659:1998)

Fatty acid composition (ISO 5509:2000)

Tocopherol composition (HPLC method with fluorescence detection)

Sterol composition (GC ISO 12228:1999 (E))

Glucosinolates (HPLC with UV-detection)

Sinapines (HPLC with UV-Detection)

Sensoric quality (DGF C-II 1 (97))

Legumes

TGW

crude protein

Cereals

TGW

hl-weight

ergot percentage

crude protein

wet gluten content

gluten index

ash and mineral content of flour

falling number

amylograph

dough elasticity

extension test

RMT-volume

wheat gluten

alpha-amylase activity

moisture content of dough

gluten index

water absorption capacity

sieve grades of barley

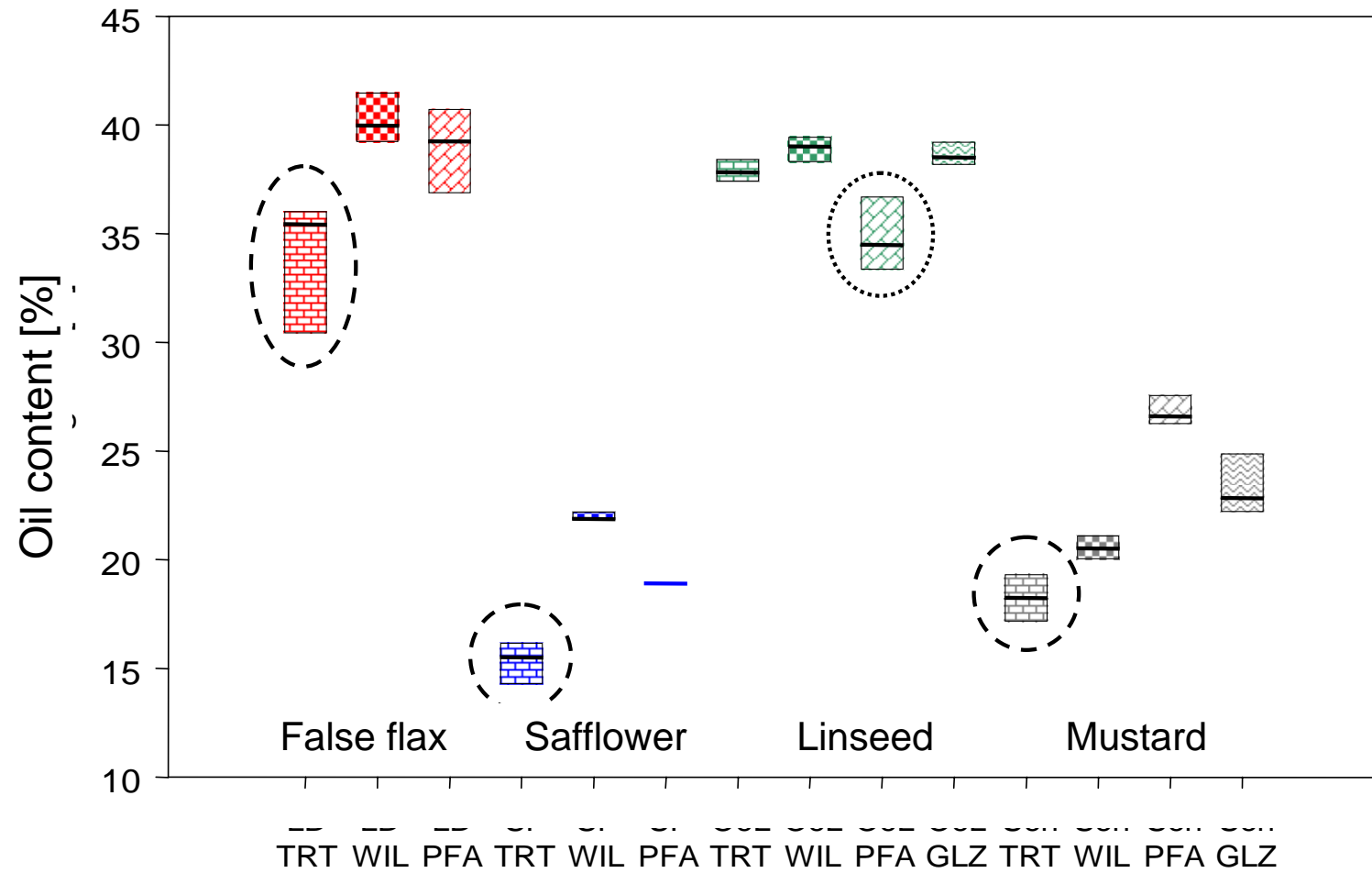

Oil content of different oil crops at different sites (Matthäus 2007)

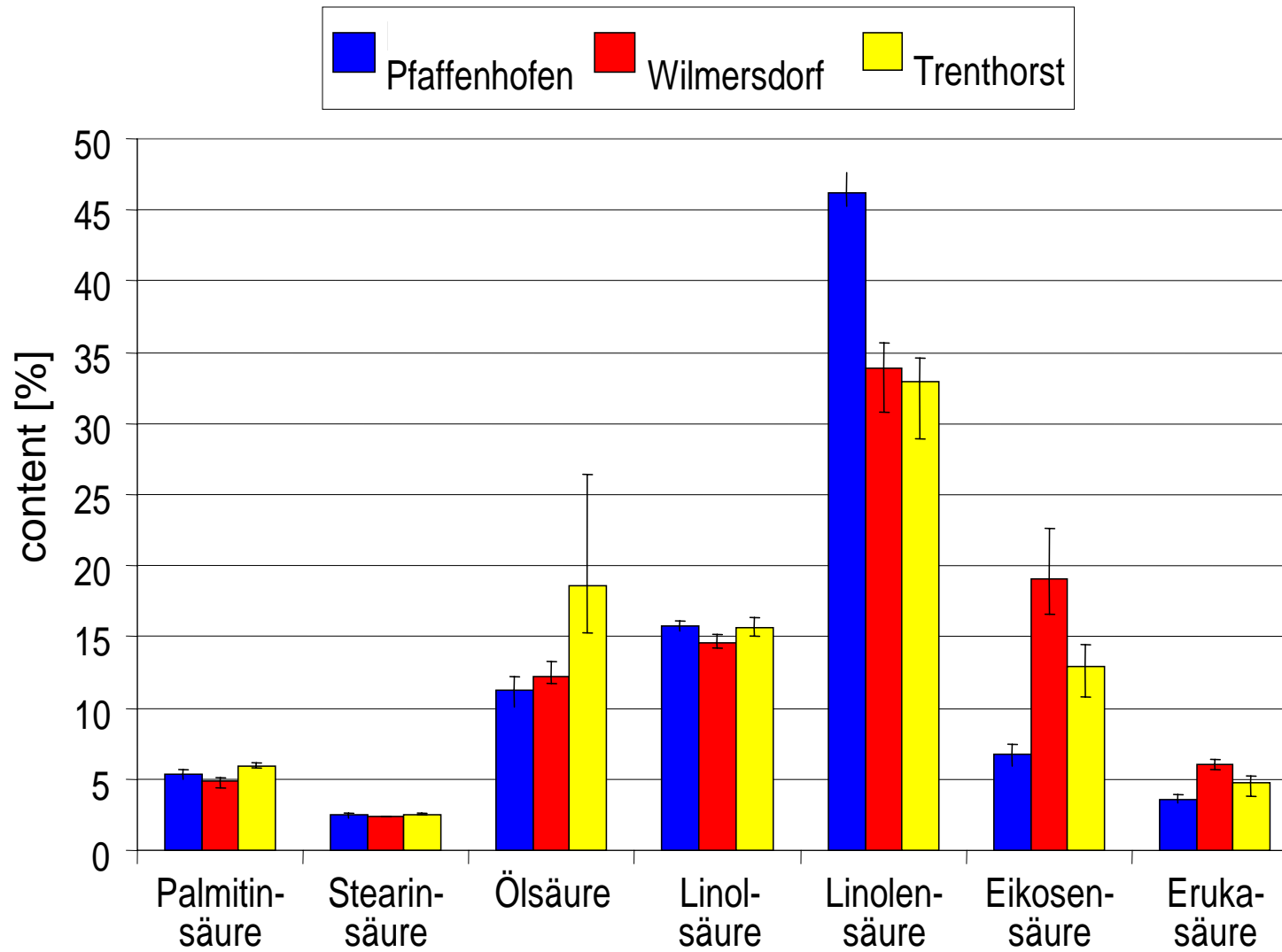

Fatty acid composition of false flax oil at different sites

Influence of mixed cropping on quality parameters of the cropping components (trials on four sites 2004/2005)

crop	parameter	sole	mixed	unit	mixed crop
wheat	crude protein	11.7b	12.8a	%	false flax. linseed
	wet gluten	24b	26a	%	
	1000 grain weight	42.7b	44.1a 42.1c	g g	false flax linseed
rye	hl-weight	74.1a	72.6b	kg	rapeseed
barley	hl-weight	62a	61b	kg	rapeseed
	sieve grades		downsized		rapeseed
linseed	oil content	37.7	38.6	%	false flax
false flax	oil content	35.5	37.5	%	linseed
	α -linolelic acid	32.7	35.8	%	linseed
	glucosinolates	16	17.3	umol g ⁻¹	pea
			18.7		lupine
			22.8		wheat
		19.1	linseed		

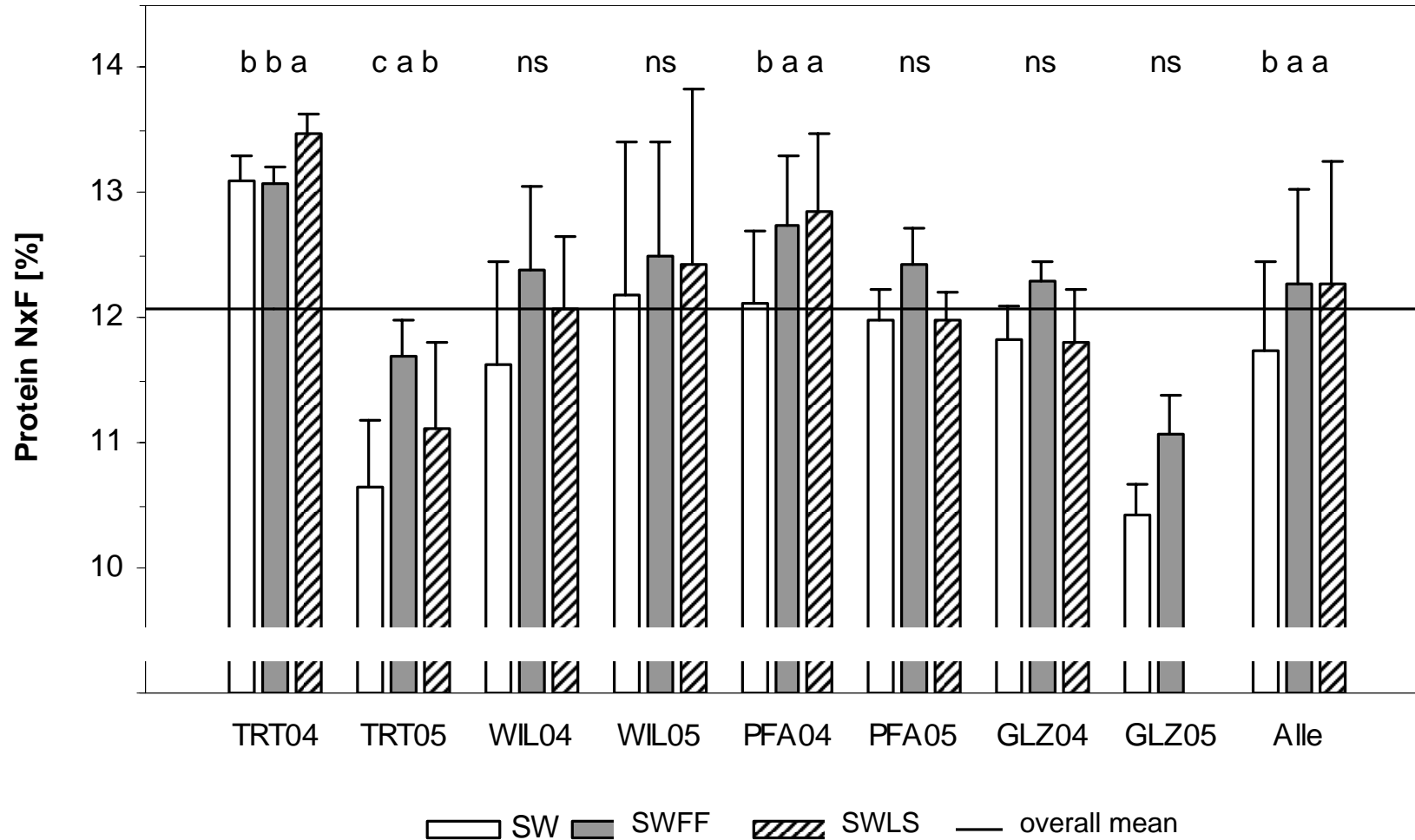

Protein contents (N x 5.7) of spring wheat kernels from sole cropping (SW) and from mixed cropping with false flax (SWFF) or linseed (SWLS) at different sites and in different years

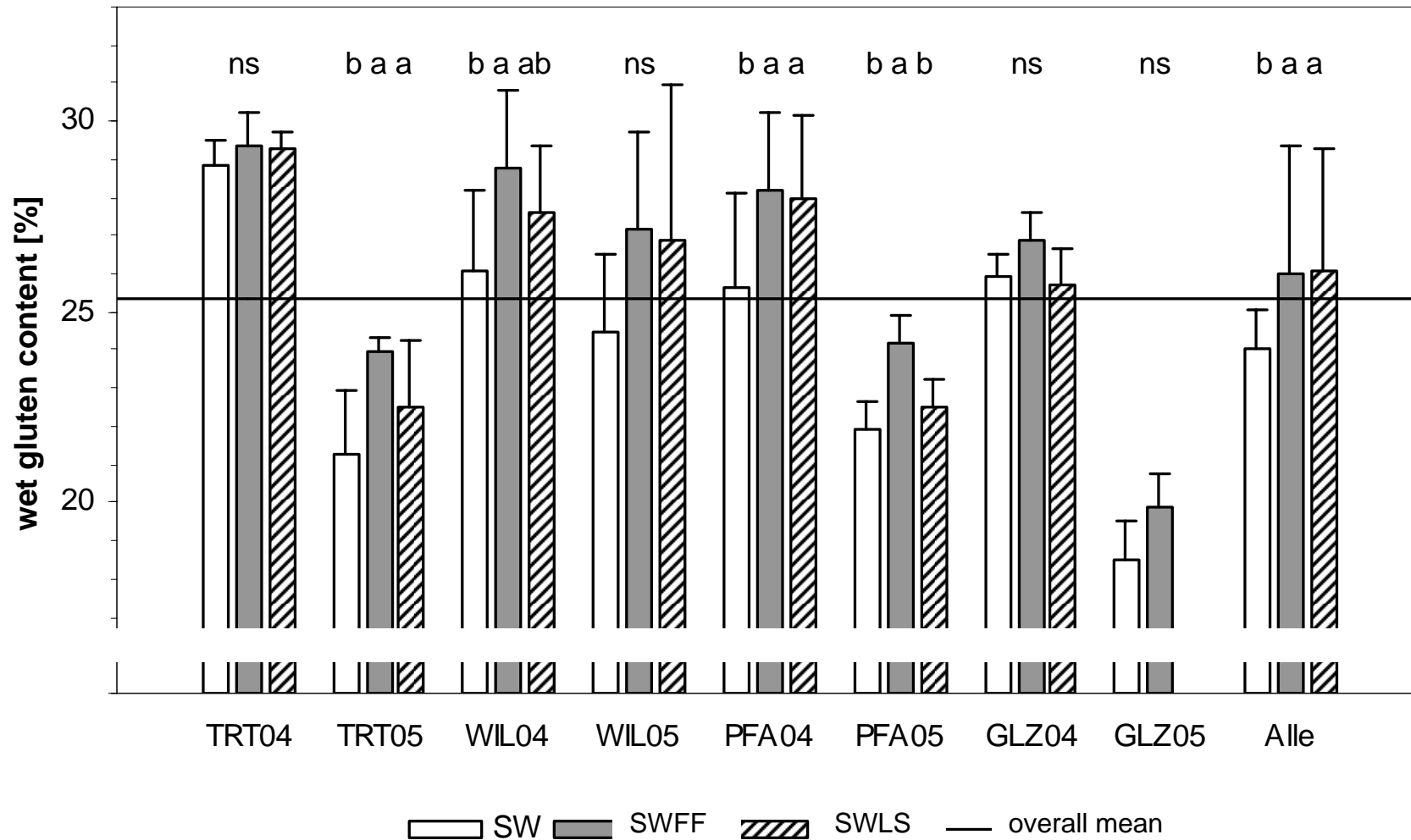

Wet gluten of spring wheat kernels from sole cropping (SW) and from mixed cropping with false flax (SWFF) or linseed (SWLS) at different sites and in different years

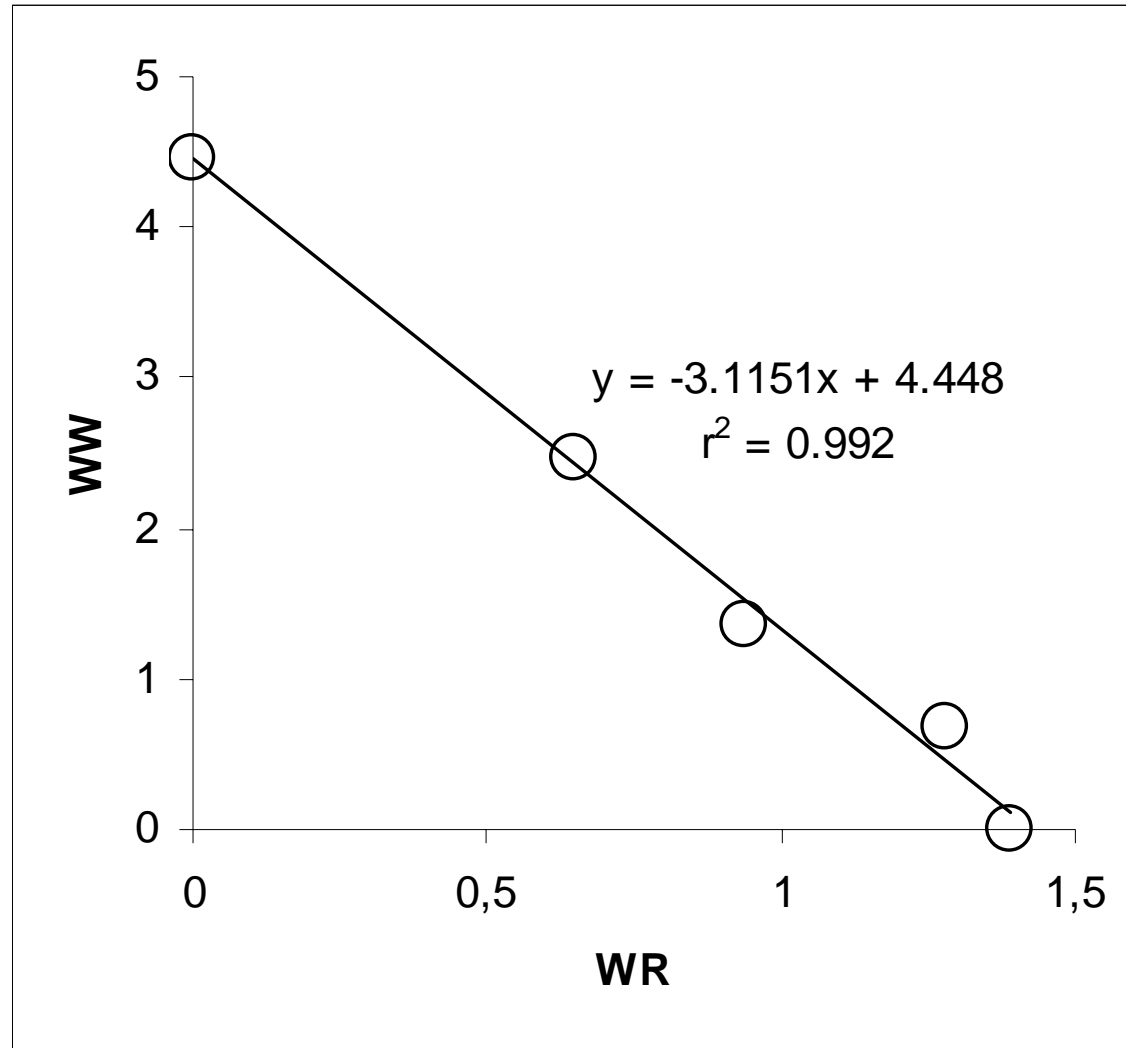

Yields of winter-rape and winter wheat in mixed cropping

Discussion and conclusions

- Very heterogeneous yield results in mixed cropping with oil seeds
- False flax is relatively stable in all mixed cropping systems. Yield levels adapted to the competitive strength of the companion crops.
- Linseed had low, and safflower and mustard high competitiveness. The mixtures of cereals with winter-rape showed no real yield advantages compared with sole cropping systems.
- Maximum oil yields of 629 kg ha⁻¹ (37% oil) in peas x false flax were reached under high depression of the pea. But at oil yields of 370 kg ha⁻¹ in peas x false flax a significant feed production (3.2 t ha⁻¹ peas) would be kept upright and oil cake is produced as a by-product. The oil yield would roughly cover the fuel demand of 3 ha farmland when used as fuel in farm machinery.
- The measured changes in quality parameters (crude protein and wet gluten in cereals, oil- and GSL-contents of seeds, alpha-linolenic-acid content in the oil) give hints on systematic competitive differences between the mixed partners compared to their sole cropping.
- This might be used to enhance quality of crops with directed mixtures. The negative effects on grain development in cereal x winter-rape mixtures indicate more strict competition situations in mixtures with winter-rape.